



ODVS05 Series
High-Precision galvanometer
Scanners
User Manual



ShenZhen HongMing Electromechanical Co., LTD

Preface

HMME(Hongming Electromechanical Co., Ltd.) is a company dedicated to the field of digital galvanometer scanners and galvanometer motors. The company boasts a professional research and development team as well as a production team.

Our main products include digital galvanometer scanners and galvanometer motors, which are widely used in industries such as laser imaging, marking machines, laser welding machines, metal 3D printing, scientific research, and medical fields. With multiple patented technologies related to digital galvanometer scanners and galvanometer motors, the company continuously provides customers with high-quality, high-performance products, and solutions through constant technological innovation and product upgrades.

Hongming Electromechanical is committed to providing professional technical support and after-sales service to customers, constantly enhancing customer satisfaction and brand influence through the establishment of a sound quality management system and after-sales service system.

Contents

Document Version Description	2
Chapter 1: Overview	3
Chapter 2: Safety Precautions	4
Chapter 3: Performance Specifications	5
Chapter 4: Structure and Wiring	6
4.1 Appearance & Adapter Cable	6
4.2 Dimensions	6
4.4 External Interfaces	7
4.4.1 XY2-100 Interface	7
4.4.2 SH2-100 Interface	7
Chapter 5: Specifications and Models	8
Chapter 6: Startup Inspection and Common Fault Analysis	8

Document Version Description

Version	Date	Modifier	Note
V1.0	2023.10	Chen Mingwei	
V1.1	2024.03	Chen Mingwei	

Chapter 1: Overview

Our galvanometer motors are designed with a dynamic magnetic structure, incorporating advanced digital encoder technology and fully digital control methods. Developed using military-grade processes and technological standards, the ODVS05 series high-precision galvanometer scanners exhibit excellent stability and strong resistance to interference. They are suitable for applications such as fiber lasers, ultraviolet lasers, and CO2 lasers.

The specific characteristics of ODVS05 Series are as follows:

- **High positioning accuracy (repeatability <1um), fast response speed, and strong anti-interference ability.**

- **Balancing speed, precision, and stability simultaneously, the galvanometer scanner can be applied in high-precision fields.**

- **The default communication protocol is XY2-100, an industry standard interface. Additionally, users can choose to use the 20Bits SH2-100 protocol or customize any interface communication protocol.**

- **Suitable applications include large-format marking and cutting, engraving, fine identification printing, precision industrial cutting and marking, as well as medical research.**

- **The entire system adopts electromagnetic compatibility optimized design, featuring high signal-to-noise ratio and strong anti-interference capability.**



Chapter 2: Safety Precautions

1、 Please ensure the environment is completely clean. Any dust or contaminants may cause damage to the mirrors.

2 、 Before turning on the device, ensure that personnel have left the scanning mirror workspace and are wearing protective goggles.

Special Reminder: Please pay attention to cleaning the protective window of the mirror, as it is a consumable and not covered by the product warranty.

Chapter 3: Performance Specifications

Accuracy and Error		
Input Aperture	10mm	12mm
Distance from the center of the outgoing light to the lower surface of the housing	34.65mm	34.65mm
Fine Marking Speed (f = 160mm)	6000mm/s	5000m/s
Fine Processing Speed	37.5 rad/s	31.25 rad/s
Step Response Time (1% Of Full Scale)	260 μ s	280 μ s
Step Response Time (10% Of Full Scale)	810 μ s	1180 μ s
Tracking Error	\leq 115 μ s	\leq 138 μ s
Repeated Positioning Accuracy	< 1 μ Rad	< 1 μ Rad
Linearity	99.9%	99.9%
Long-term drift over 8 hours	< 0.1mRad	< 0.1mRad
Gain Drift	< 8PPM/ $^{\circ}$ C	< 8PPM/ $^{\circ}$ C
Zero Drift	< 15 μ Rad/ $^{\circ}$ C	< 15 μ Rad/ $^{\circ}$ C
Laser System Integration		
Maximum Pulse Laser Power	100W	
Mirror Reflective Wavelength	355nm、1064nm	
Power Supply and Signals		
Power Requirements	\pm 15VDC	
Operation Current	3A	
Interface Protocol	XY2 -100、SH2-100、SPI	
Mechanical Scanning Angle	\pm 22 $^{\circ}$	
Temperature, Dimensions		
Operation Temperature	10 $^{\circ}$ C ~45 $^{\circ}$ C	
Storage Temperature	-10 $^{\circ}$ C ~60 $^{\circ}$ C	
Laser Input Aperture	14mm	
Dimensions (Length x Width x Height)	120 \times 137 \times 136mm	
Weight	about 4kg	

Chapter 4: Structure and Wiring

4.1 Appearance & Adapter Cable



4.2 Dimensions

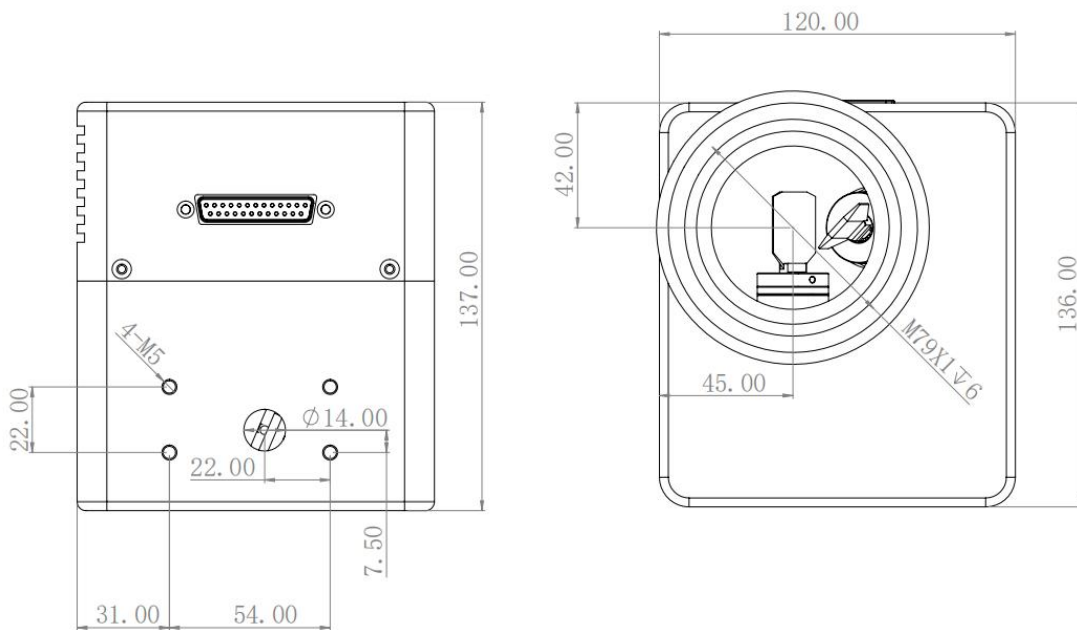

4.4 External Interfaces

4.4.1 XY2-100 Interface

The ODVS05 series defaults to the XY2-100 protocol interface. This protocol is currently the mainstream communication protocol, with a resolution of 16 bits. The XY2-100 interface can be connected to mainstream control cards in the industry via the XY2-100 scanning mirror data cable. The pin signals on the ODVS05 interface are as follows:

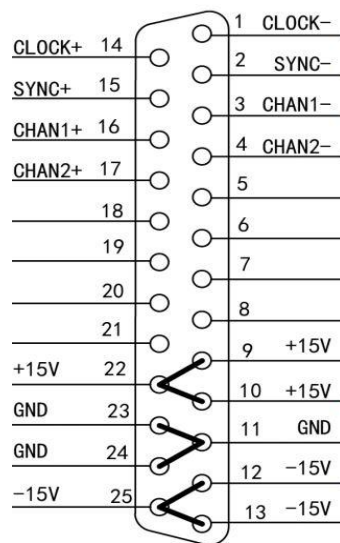

4.4.2 SH2-100 Interface

The ODVS05 series can utilize the SH2-100 protocol. This protocol is compatible with the 20-bit SL2-100 communication protocol. This enables the ODVS05 to communicate at high resolution with control cards such as the RTC series, allowing for additional functionalities. Under this protocol, the ODVS05 needs to be connected using an SH2-100 adapter cable. The pin signals for this protocol interface are as follows:

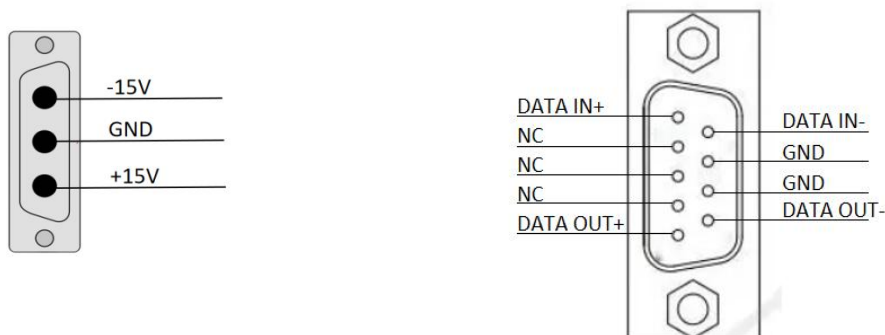

Chapter 5: Specifications and Models

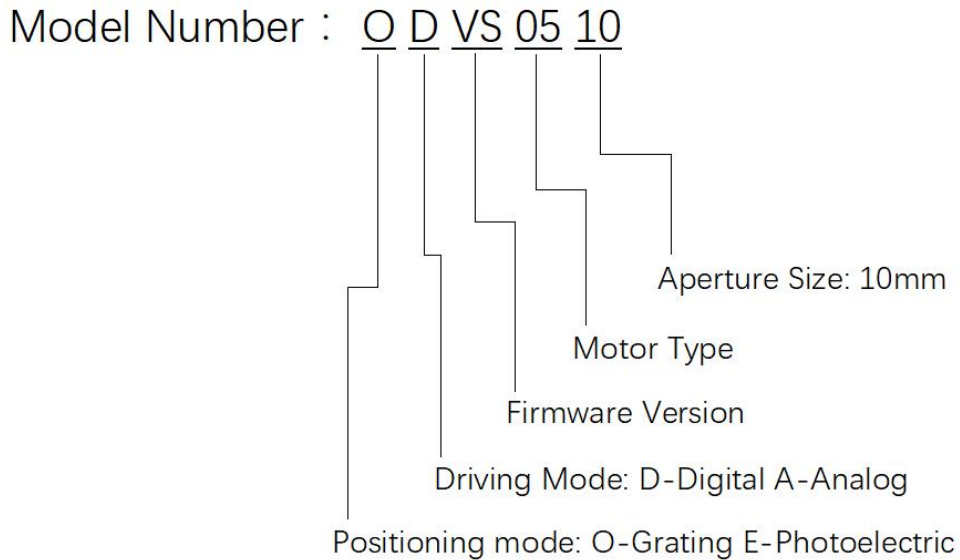

Chapter 6: Startup Inspection and Common Fault Analysis

Before powering on, it is essential to check the entire system for loose plugs, misinsertions, collisions between mirrors, incorrect drive signals, and power input errors. Only after confirming that everything is in order should the power be turned on.

Symptoms of Malfunction	Causes	Solutions
The system shows no response.	The power supply is not connected or the switch is not turned on.	Check the power supply connection.
After startup, the red light is constantly on accompanied by a clicking sound.	Limit protection activated.	Check if the input signal amplitude is too high. If the input signal is normal, please contact our company.
After startup, the scanning motor keeps vibrating slightly.	The interference is too strong or the input signal is floating.	Check the source of interference and input signal lines.

After startup, the motor whines, and both the drive board and motor heat up.	Check if the drive board is properly connected to the motor / whether the connector or mirror is loose	Check the wiring / check the mirrors and clips
--	--	--

Special Note:

1. Before powering on, please carefully check whether the wiring sequence of the external connection lines of the scanning mirror is correct, otherwise it may affect the normal operation of the mirror or cause damage.
2. The two motors must be connected to the corresponding sockets on the drive board according to the matching sequence number. They cannot be interchanged, otherwise self-excitation may occur.
3. Do not adjust the hardware configuration such as the potentiometer on the board without authorization, and do not disassemble the scanning mirror components without authorization.

ShenZhen HongMing Electromechanical Co., LTD

Address: B705-2, Yousong Technology Building, No. 108 Donghuan 1st Road, Longhua District, Shenzhen, China

Postal Code: 518000

Telephone: 400-859-7098

Email: support@hmmescan.com